

[www.centralemangueras.com.co](http://www.centralemangueras.com.co)

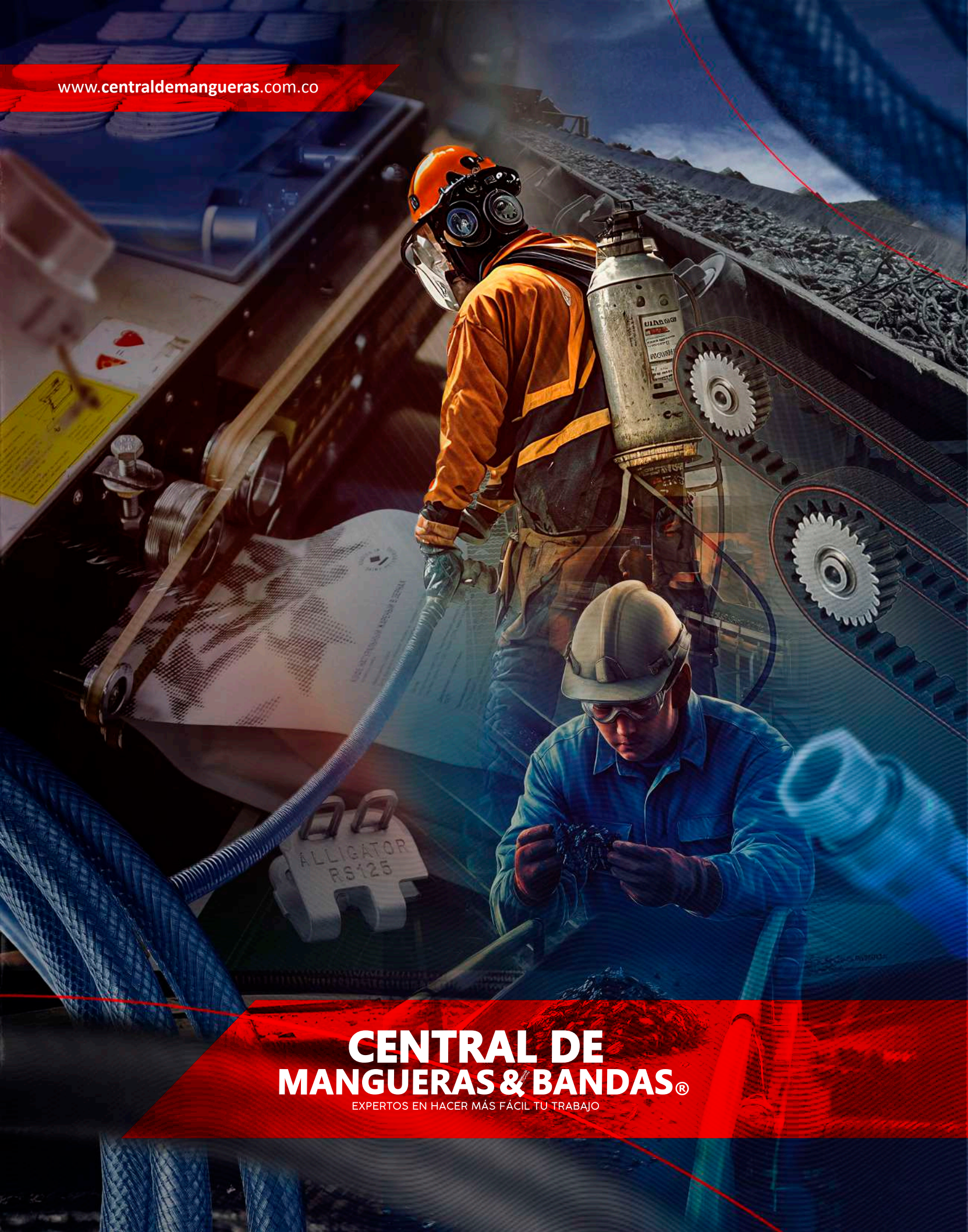

# CENTRAL DE MANGUERAS & BANDAS®

EXPERTOS EN HACER MÁS FÁCIL TU TRABAJO

# INDICE

**4** Hydraulic  
Hoses

**5** Industrial  
Hoses

**6** Composite  
Hoses

**7** Flexible Metallic  
Hoses

**8** Hydraulic  
Connections

**9** Industrial  
Connections

**10** Hose  
Accessories

**11** Hose  
Services

**12** **Conveyor**  
Belts

**13** **Conveyor**  
Belts

**14** Rubber and  
**Fabric Belts**

**15** Rubber and  
**Fabric Belts**

**16** **Conveyor**  
Belt accessories

**17** **Conveyor**  
Belt accessories

**18** Conveyor Belt  
**Technical Service**

**19** Technical Inspections in  
**Conveyor System**

**20** Power  
**Transmission Belts**

# HYDRAULIC HOSES

*Maximum performance in every application. Maximum reliability in every connection.*

We maintain a comprehensive inventory of hydraulic hoses engineered to operate in pressure ranges from 0 to 17,000 psi and temperatures from -60 °C to 155 °C, fully compliant with international standards such as SAE, EN, DIN, and MSHA.

Our next-generation hoses provide enhanced efficiency and sustainability, featuring reduced bend radius, higher pressure tolerance, more abrasion-resistant covers, and cutting-edge technology developed according to ISO 18752 standards.



High pressure capacity



Compact bend radius



Wide temperature range



International standards compliance



Durable covers



Advanced technology

# INDUSTRIAL HOSES

*Maximum durability for extreme industrial conditions.*

We offer a wide range of industrial hoses for the **safe** and **efficient** transfer of fluids and materials, including **water, air, petroleum products, abrasives, cement, shotcrete, asphalt, steam, chemicals,** and food-grade substances.

Manufactured with advanced production technology, our hoses deliver high operational **safety** and **performance**, resistant to over 1,400 industrial chemicals.



**Specialized solutions** are available for demanding sectors such as mining, well drilling, port facilities, and heavy industry.

# COMPOSITE HOSES

*Flexible, lightweight, safe,  
and high-performing.*

Engineered for the transfer of hydrocarbons, biofuels, chemicals, petrochemicals, petroleum, oils, liquefied gases, and food products, composite hoses ensure reliable suction and discharge at both high and low pressures.

**Hoses of  
the future,  
engineered  
for today's  
challenges.**



Their multi-layered construction—comprising internal and external spirals of galvanized steel, stainless steel, aluminum, or polypropylene-coated materials, combined with fabric and thermoplastic inner liners—absorbs **vibrations and compensates for misalignments in transfer systems.**

Known as **'the hoses of the future,'** they stand out as the most flexible and lightweight on the market, available in diameters from 3/4" to 12.



Super  
resistant



Lightweight  
and flexible



Versatile  
use



Vibration  
compensation



Wide range  
of sizes



# FLEXIBLE METALLIC HOSES

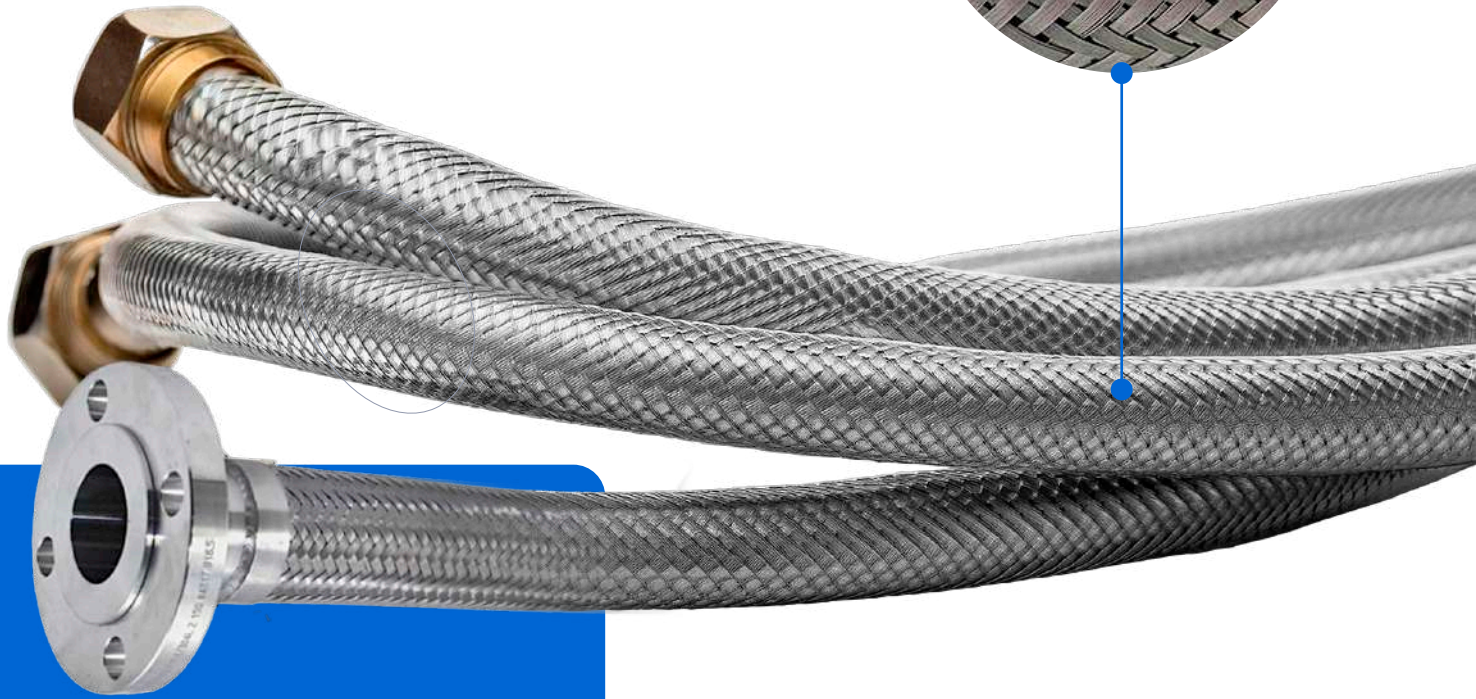

Flexible stainless-steel hoses, ideal for industrial applications requiring high resistance to extreme temperatures, abrasive chemicals, vibrations, or misalignments between equipment and piping.



Their annular construction with closed corrugation ensures excellent flexibility and durability, as well as outstanding corrosion resistance against a wide variety of fluids. Available without braid, with single or double stainless-steel braid, in versions

**304** | **316** | **321**

Flexible stainless-steel hoses, ideal for industrial applications requiring high resistance to extreme temperatures, abrasive chemicals, vibrations, or equipment misalignment. Available from ¼" to 12", with varying assembly pressure capacities.

# CONNECTIONS

## HYDRAULIC HOSES COUPLINGS

We have a wide range of permanent and reusable couplings, compatible with hoses of different pressure ranges, **from 0 up to 17,000 psi.**

They are available in metallic and stainless-steel materials, with special coatings that guarantee **greater resistance** to corrosion.



Female couplings



Male couplings



Flanges

Available in multiple sizes

Ball-type hydraulic couplings

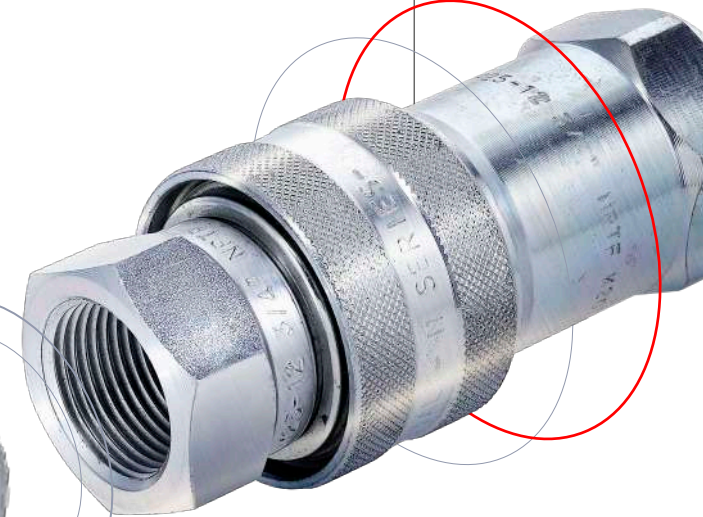

Manufactured under strict international standards, our couplings incorporate innovative technologies that **ensure a reliable, leak-free assembly**, optimizing the performance of the hydraulic system.

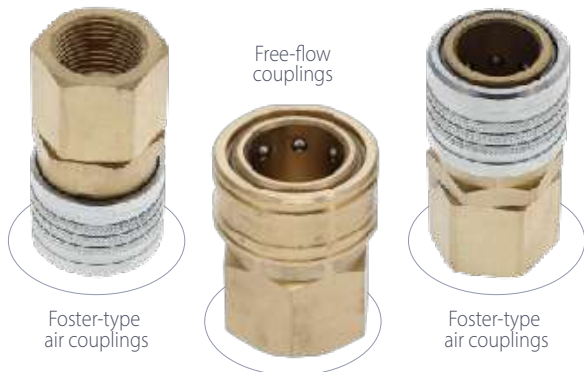

# CONNECTIONS FOR INDUSTRIAL HOSES

We offer a variety of special connections for **industrial hoses**, including half-turn quick coupling systems, quick couplings, Push Lock type, Camlok, and quick cam couplings in configurations A, B, C, D, E, and F.

We also provide threaded connections such as **'BOOS'**, combined nipples, couplings, and Victaulic clamps, ideal for shotcrete



We have a complete line of standard quick fittings in both metric and inch sizes, specially designed for pneumatic hoses.

# HOSE ACCESSORIES

We offer a complete line of accessories designed to maximize the performance of your hoses, adapting to diverse pressure requirements, extreme conditions, and industrial environments. Here you will find the solutions you need for reliable and professional assembly.

---

Grenades



Whip-check cables



Pressure wash guns



Hose clamp ties

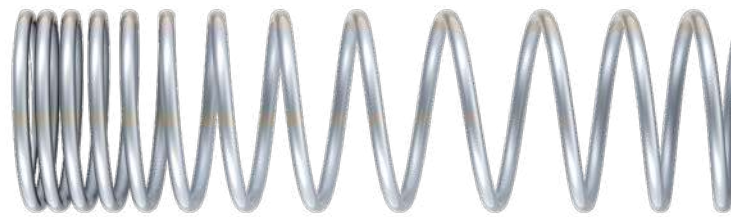

Steel spiral guard



Steel, PVC, and abrasion



Resistant nylon spiral guards



MSHA Save-Sleeves (flame-resistant, high-temperature protective covers ISO 3457)



# HOSE SERVICES

---

From assembly to diagnostics, we provide complete support to keep your operation running without interruptions. Hydraulic and flexible metallic hose assembly

---

**Hydraulic hose assembly** ◀

**Flexible metallic hose assembly** ◀

**Specialized hose services** ◀

Technical inspections, technical assessments on mobile and stationary equipment, and other diagnostic aids

**Test bench** ◀

**Training in hydraulic systems** ◀

**Leak detection kit** ◀

**Equipment analysis** ◀

(Senso Control) for monitoring and diagnostics of hydraulic systems

# CONVEYOR BELTS

We distribute synthetic belts for light conveying, manufactured with premium materials such as:

PVC

PU

POz

Backed by leading international brands.

---

Backed by leading international brands.

---

Synthetic conveyor belts are efficient, durable, and versatile solutions for product handling in production lines. We offer a wide portfolio designed to adapt to various industrial applications, featuring smooth or rough surfaces, high resistance to wear, oils, chemicals, and elevated temperatures. In addition, we provide easy-to-clean belts, ideal for processes with strict sanitary requirements, as well as belts with a low coefficient of friction, contributing to greater energy efficiency in conveying systems.



## Industrial Applications

A solution for every industry



Food industry



Fitness



Meat processing



Agro-industrial



Textile



Wood industry



Bulk products



Paper industry



Printing and packaging



We also carry out **custom fabrications** according to customer requirements, incorporating elements such as cleats, guides, and corrugated sidewalls (Sidewall) to **improve conveying control and efficiency.**

We offer specific solutions for inclined conveying applications and high-temperature conditions, ensuring **optimal performance** even in the most demanding environments.



### **Certifications for the Food Industry**

Hygiene, safety, and  
compliance at the  
highest level.

---

All our food-grade products  
comply with:

**FDA / CE 1935/2004 / Directiva  
2002/72/CE / UE 10/2011**

---

We comply with the highest  
international standards for  
food contact.

# RUBBER & FABRIC BELTS

Belts that **withstand** what others cannot. **Guaranteed performance** in the most extreme environments.

Belts designed for heavy-duty applications, manufactured with high-quality raw materials.

They withstand extreme conditions such as:

- Severe abrasion
- Oil exposure
- High temperatures
- Fire resistance (flame-retardant)
- Inclined conveying"

High-demand applications require reliable solutions. Our line covers industries that cannot afford failures.



## **Anti-abrasive:**

Designed to withstand extreme wear conditions, ideal for mining, quarries, and applications with highly abrasive materials.

## **Profiled conveyor belts:**

Recommended for inclined conveying, as their textured surface allows a greater angle of inclination without loss of adhesion. Power, durability, and performance Bucke



# Power, durability, and performance

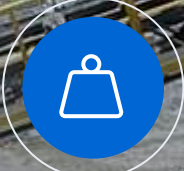

## **Elevator Belts:**

Specifically developed for bucket elevators, providing excellent traction and resistance in vertical applications.

## **Rubber:**

We supply rubber skirts and sheets for roller lagging, gaskets, and tank protection, ensuring durability.

# CONVEYOR BELT ACCESSORIES

We offer a complete line of accessories and components to **optimize the performance, durability, and versatility** of conveyor belts in various industrial applications.

## BUCKETS



Manufactured in high-density polyethylene or polyamide (nylon), ideal for bulk material handling systems. Their design ensures efficient material discharge. Commonly used for the elevation of cereals, animal feed, oilseeds, sugar, and more.

## PROFILES

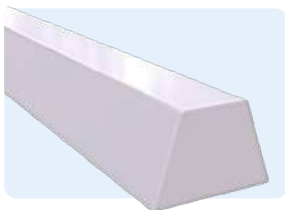

### GUIDES

Trapezoidal in shape, they serve for centering and product guiding and can also function as low-height cleats. Made of PVC, available in green or white.

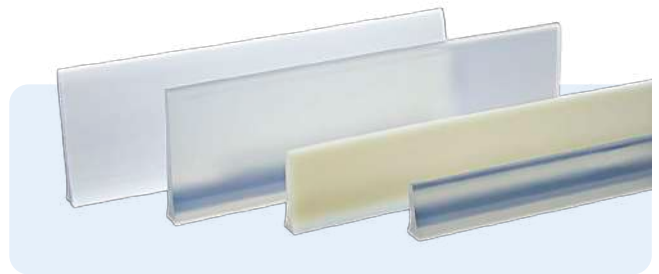
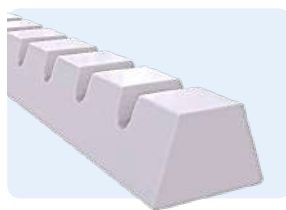

### CLEATS

Designed to convey packaged or bulk products on belts with inclinations up to 70°. Available in heights from 30 mm to 80 mm, in green or white, ideal for industrial and food applications.

## Splicing PLATES

Non-abrasive, non-magnetic, and silent splicing, easy to install, remove, and clean.

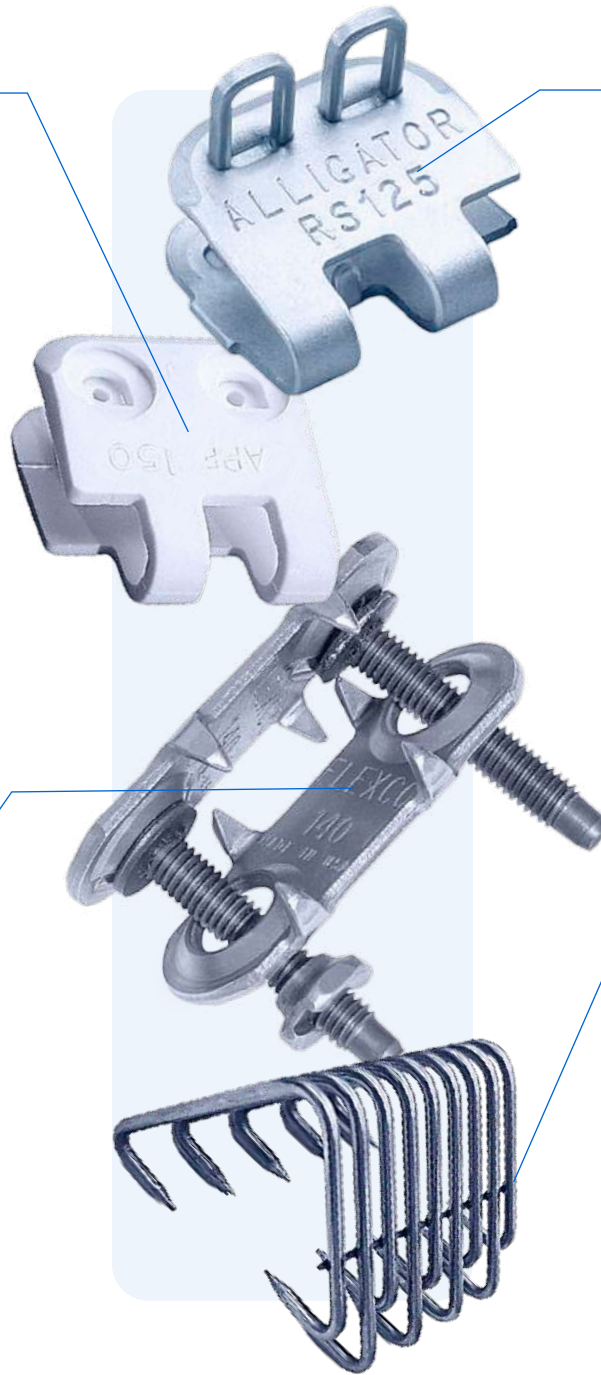

## Metal Splicing PLATES

Available in steel and stainless steel, with beveled edges and embedded staples that ensure smooth transition and compatibility with the conveyor system.

## FASTENERS

The solid plate bolted fastener system provides a strong, leak-free splice, ideal for high-tension and heavy-load applications.

## HOOK FASTENERS

Available in stainless steel or galvanized steel, in Unibar formats or carded hooks, with a variety of diameters, lengths, and styles to suit different applications.



## COLD VULCANIZING ADHESIVE

Specialized adhesive for cold vulcanization processes, designed for rubber conveyor belts, both flat and corrugated. It ensures a strong and durable bond without the need for heat, making repairs and splicing efficient, whether in the field or in the workshop.

A close-up photograph of a worker wearing a white hard hat, safety glasses, and a grey long-sleeved shirt. The worker is focused on their task, using a power tool with a large, circular abrasive disc to work on a dark, heavy-duty conveyor belt. The worker is wearing silver safety gloves and yellow protective sleeves on their arms. The background shows a construction site with concrete pillars and wooden beams, suggesting an industrial or mining environment.

# TECHNICAL SERVICES FOR **CONVEYOR BELTS**

- ▶ Splicing and vulcanization of heavy-duty belts
- ▶ Splicing service for synthetic belts
- ▶ Splicing service for wide flat belts



# TECHNICAL INSPECTIONS IN **CONVEYOR** **SYSTEMS**

- Training in conveyor systems ◀
- Pulley and roller lagging ◀
- Roller lagging service ◀
- Installation of conveyor belts and accessories ◀
- Installation of carrying rollers ◀
- Installation of impact rollers ◀
- Installation of return rollers ◀
- Installation of tail rollers ◀
- Installation of troughing idlers ◀
- Installation of cleaning equipment ◀
- Maintenance of cleaning equipment ◀

# POWER TRANSMISSION BELTS

Power that connects,  
efficiency that drives.

## We supply:

Classical and cogged V-belts

- Type A, B, C, D, E, and M
- Type SPZ, SPA, SPB, and SPC
- Wedge belts 3V, 5V, and 8V
- Powerband / banded belts
- Perforated and link belts
- Variable speed belts
- Synchronous belts of all types
- Agricultural belts
- Belts with special coatings
- Flat belts
- Thermoweldable round and special belts (Polycord)

We offer the best and most **complete line of industrial V-belts**, manufactured to ensure reliable performance in power transmission. We provide solutions for both **heavy-duty and light-duty service**, adapted to diverse operational requirements.





## TRUST THAT MOVES INDUSTRIES

We distribute quality, we guarantee performance.

Representatives of internationally recognized brands, backed by high standards of quality and durability. Our portfolio is designed to cover a wide range of sectors with efficient, durable, and easy-to-maintain solutions.



### Power Transmission Belt Service

Technical inspections and power transmission assessments.

---

power transmission assessments.

# ON-SITE SOLUTIONS

We have 12 branches strategically located in Colombia's main cities, allowing us to provide nationwide coverage and promptly meet our customers' needs.

Our service modalities include:

## In-house Projects:

We develop solutions directly at the customer's facilities, with specialized technical staff and dedicated resources, ensuring agile, continuous service adapted to their operational processes.

## Consignment Stock:

We facilitate product supply through consignment schemes, allowing our customers to maintain available inventory without affecting cash flow, with invoicing only for the consumption made during the established periods.

## Crimping Machine on Loan:

We provide crimping equipment on loan, installed at the customer's facilities at no rental cost, under the condition of meeting a minimum consumption of supplies and/or hoses, as contractually agreed.



**These modalities are designed to provide flexibility, operational efficiency, and continuous support to our strategic partners.**



**CENTRAL DE  
MANGUERAS & BANDAS®**  
EXPERTOS EN HACER MÁS FÁCIL TU TRABAJO



## Our Branches

Medellín  
Barranquilla  
Bogotá  
Bucaramanga

Cartagena  
Cali  
Cúcuta  
Dosquebradas

Sogamoso  
Rionegro (ANT)  
Girardota (ANT)  
Santa Marta

Call us

**(604) 2321280**

[cotizaciones@centraldemangueras.com.co](mailto:cotizaciones@centraldemangueras.com.co)

[www.centraldemangueras.com.co](http://www.centraldemangueras.com.co)